

NOTE: DIMENSIONS IN ARE IN INCHES.

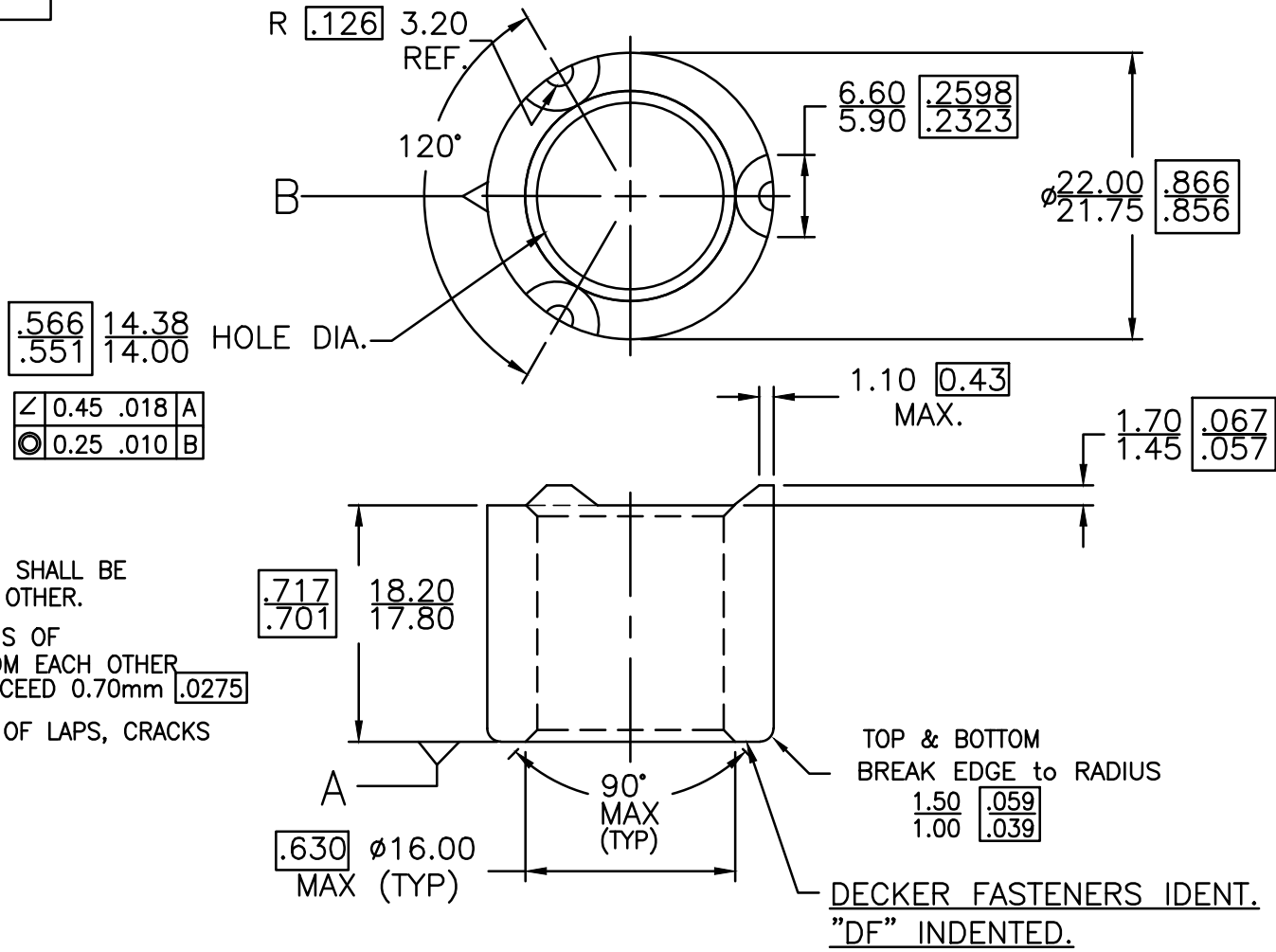

NOTES:

1. HEIGHTS OF WELD PROJECTIONS SHALL BE WITHIN 0.15mm 006 OF EACH OTHER.
2. THE DISPERSION OF THE WIDTH'S OF PROJECTIONS FOR WELDING FROM EACH OTHER IN ONE (1) NUT SHALL NOT EXCEED 0.70mm .0275
3. ALL SURFACES SHALL BE FREE OF LAPS, CRACKS SEAMS, BURRS AND VOIDS.

$\frac{.566}{.551}$	$\frac{14.38}{14.00}$	HOLE DIA.
\angle	0.45 .018	A
\odot	0.25 .010	B

C/N	S	CHANGE	DATE	DR	CH	OK
	A					
	B					
	C					
	D					
	E					



CONFIDENTIAL

THIS DOCUMENT IS THE EXCLUSIVE PROPERTY OF DECKER MANUFACTURING CORPORATION AND IS TO BE RETURNED TO THE COMPANY UPON REQUEST. THE CONTENTS ARE NOT TO BE USED IN ANY MANNER DETRIMENTAL TO THE INTERESTS OF THE COMPANY. THEY ARE NOT TO BE DISCLOSED OR REPRODUCED IN WHOLE OR IN PART WITHOUT EXPRESSED CONSENT.

PART NAME WELD NUT - ROUND		
CUSTOMER PART NO.		
MATERIAL C1010 STEEL		
FINISH PLAIN		SCALE 2xSIZE
DRAWN BY * MAK	DATE 9/18/09	PART NO.
CHECKED BY	APPROVED BY	625-8650